

RESEARCH ARTICLE

DESIGN AND DEVELOPMENT OF A MICROSTRIP PATCH MONOPOLE ANTENNA FOR WIDE BAND SPECTRUM

Manish Kumar Vishnoi^{*1}, Zakir Ali², Vinod Kumar Singh³, Anil Kumar Verma⁴

Department of ECE¹, Bhagwant Global University, Kotdwar - 246149, Uttarakhand, India.

Department of ECE², IET Bundelkhand University, Jhansi - 284128, Uttar Pradesh, India.

Department of ECE³, SR Group of Institutions, Jhansi - 284419, Uttar Pradesh, India.

Department of ECE⁴, PDSCT, Chhatarpur - 471001, Madhya Pradesh, India.

Article History

Received: 13 September 2025

Revised: 18 November 2025

Accepted: 01 December 2025

Published: 25 December 2025

Corresponding author

Manish Kumar Vishnoi
Department of ECE,
Bhagwant Global University, Kotdwar -
246149, Uttarakhand, India.
Email- vishnoi71981@gmail.com

ABSTRACT: The simulation and design together with the performance features of a microstrip patch antenna in wide frequencies range 4.57- 9.85 GHz are presented in this paper to meet the growing demands of communication systems which are supposed to be operating in different frequencies range. The proposed antenna will have a low profile and small size that is compatible with the existing communication devices. Pertinent electromagnetic simulation solvers named CST are used to analyse the performance of the antenna and verify them. These findings demonstrate the level of effectiveness with which the designed antenna can cover broad wideband with a stable and efficient radiation pattern across broad bandwidth. The suggested antenna will be applicable in the wide frequency range applications such as cognitive radio, satellite communication and wireless communication. Their size is small, and their installation is simple thus they can be installed in places of small space.

Keywords: Microstrip patch antenna; Wideband antenna; CST simulation; Broadband radiation characteristics; Compact antenna design; Wireless and satellite communication systems.

INTRODUCTION

The growing needs of small size low profile and high efficiency antennas are due to wireless communication technologies and the emergence of wearable devices. The microstrip patch antennas (MPAs) have received significant interest in the recent past since they are low profile, low weight, relatively simple to produce and can be applied in either planar or non-planar structures [1, 2]. Their characteristics render them useful to gain acceptance in WLAN, UWB, and other unexploited areas of the IoT and AI [10, 14]. The assurance of the small size, the higher bandwidth, and the needed radiation characteristics simultaneously, however, remains an issue. A combination of various has been used in addressing these challenges.

Design methods such as the use of defected ground structures (DGS) [11], stacked configuration [2] and novel slot shapes [13]. To cite an example, in DGS-designs, the behaviour of the antenna in relation to the bandwidth and radiation efficiency is realised by the use of controlled perturbations in the ground plane [12]. Similarly, the antenna characteristics such as bandwidth, gain, and efficiency have been advanced through the use of parasitic elements and the enhanced techniques of feed [6], [7]. The substrate material and shape are also the most important factors that determine the antenna properties. As an illustration, Low loss substrate like Rogers material is applied to enhance the dielectric characteristics, and low signal losses due to substrate thickness; it was found out that the optimum

substrate thickness resulted into reduced losses and also minimized return loss [5]. Additionally, with the end of modeling and extending the parameters of the antenna, various neural network methods have been introduced in [3]. Safety factor such as SAR, flexible material have been of interest in designs of wearable antennas. Out of these types of textual antennas, health monitoring and remote healthcare facilities has attracted much attractiveness due to them being comfortable, flexible and have very low electromagnetic effects on human body [17]. The latest advances are some circular polarized designs of the signal which can be stable in the dynamic fields and multi banding so that the system can serve more than one purpose [16, 17]. Out of these, the current paper derives the idea of the new antenna in which the advanced DGS techniques and different shape of slits are included to broaden the bandwidth and minimise the size. This design is to serve the growing need in the current and the near future systems of wireless communication towards the IoT, wearable and health monitor technologies.

DESIGN OF PROPOSED ANTENNA

The proposed design is compact and low profile and therefore well suited to be integrated into modern day, compact communication equipment that do not have much space. The monopole design adopted in this study mainly enhances the bandwidth for the wider range of 4.57 GHz to 9.85 GHz. It also assists in increasing the gain and the radiation characteristics of an antenna (Fig. 1a and 1b).

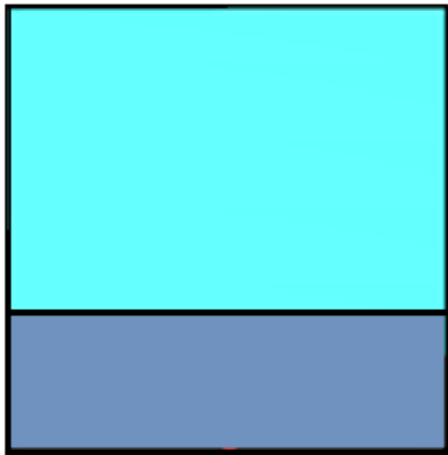

FIG. 1(A): GROUND PLANE

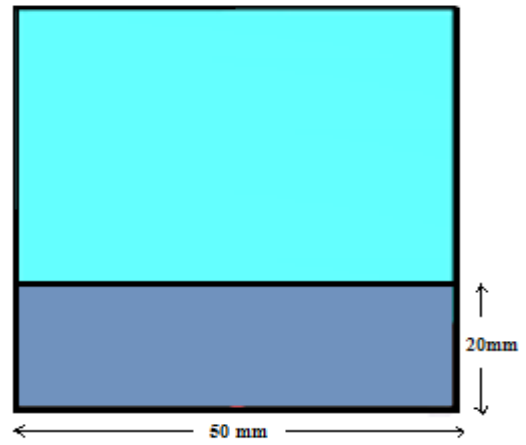

FIG. 2: GROUND PLANE DIMENSIONS

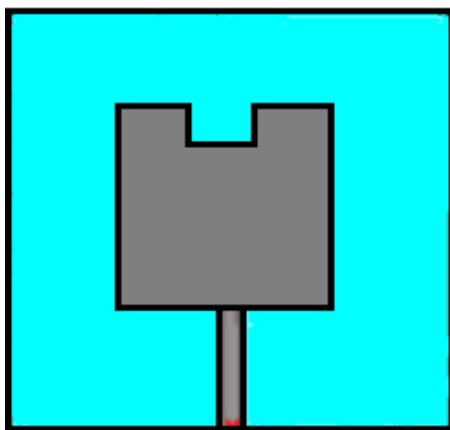

FIG. 1(B): PATCH ANTENNA

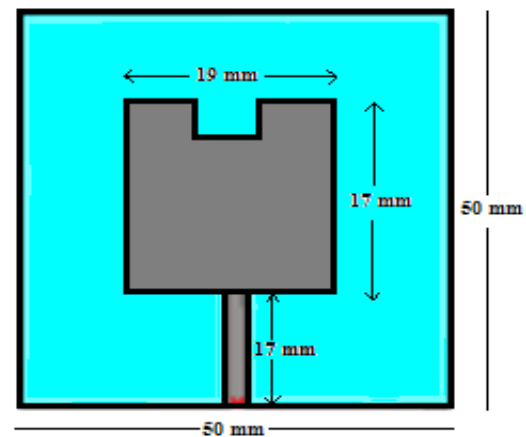

FIG. 3: PATCH AND SUBSTRATE DIMENSIONS

The ground plane size is determined by the exact specification of the antenna design and the operating frequency of the antenna. The length of the ground plane, width with the shape of the rectangle, 20mm by 50mm, is important in the resonance frequency and radiations of the antenna (Fig. 2). Patch Width 17 mm and Length 19 mm which is calculated by online microstrip patch antenna calculator or mathematical formulas as below. The design substrate material that is chosen in this case is jeans. The substrate parameters in the next sections refer to the parameters of the material on which the antenna patch will be placed. This one here is the capability of the substance to hold electrical energy in a field of electricity. According to the low dielectric constant of 1.6, it is said that the permittivity of the jeans material is also small. It produces higher bandwidths and lower resonant frequency with lower dielectric constants that are at times suitable in certain applications. The effect of this kind of material is to control the overall mechanical and electrical characteristics of the antenna. When buying jean, some benefits could be enjoyed like price, versatility, etc. The antennas with low dielectric constant such as 1.6 can have broader bandwidth that can be used in areas where it is necessary to have the device able to switch frequencies. The resonance frequency of the antenna and the matching impedance are determined by the accurate positioning of the feed point. The dimensions of the feed line are width=2.5mm, Length=17 mm (Fig. 3).

RESULTS AND DISCUSSION

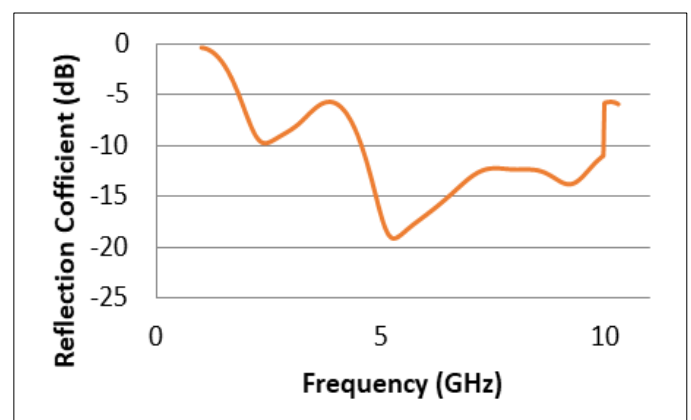

FIG. 4: S11 PARAMETER PLOT

Precisely, in both microwave and radio frequency engineering, the scattering parameters are a collection of measures that is frequently utilized to characterize the reaction of linear electrical circuits. These properties define the transmission and reflection of electrical signals at various network terminals, including an antenna, amplifier or filter. The s-parameters can be very useful when it comes to analysing the effectiveness of individual components that would be applied in applications where a high frequency is needed (Fig. 4). The bandwidth is

most commonly defined as the band of frequencies that an antenna can effectively work at. When the microstrip patch antenna used in the abstract of this paper is considered, the bandwidth is provided as 4.57 GHz to 9.85 GHz.

CONCLUSION

The design, simulation and numerical performance analysis of a microstrip patch antenna have been presented in this paper. The most visible property of the antenna is the fact that the working frequency is between 4.57 GHz and 9.85 GHz. This allows it to meet the rising need of the communication systems operating within various frequency bands. The small size and low complexity of the antenna meets the requirements of the modern uses and also meets the requirements of the communication devices. Due to the findings of the analysis, it can be said that the antenna can supply the entire 3.4 GHz range with the appropriate bandwidth and constant and fixed emission properties. Besides this, the antenna size is small, and it can be easily integrated in such environment which makes the antenna appropriate when space is a constraint. This success of this antenna design can justify the reason why it can be used in the many demand of the current wireless communication technologies.

ACKNOWLEDGEMENT: Nil

CONFLICT OF INTEREST: Nil

REFERENCES:

1. Agrawal NP, Kumar G, Ray KP. Wide-band planar monopole antennas. *IEEE Trans Antennas Propag.* 1998;46(2):294–295. doi:10.1109/8.660976.
2. Yadav A, Singh P, Verma RK, Singh VK. Design and comparative analysis of circuit theory model based slot loaded printed rectangular monopole antenna for UWB applications with notch band. *Int J Commun Syst.* 2022;36(3). doi:10.1002/dac.5390.
3. Saxena A, Singh VK. Design of compact array antenna and its effect on human brain. *Wireless Pers Commun.* 2022;125:637–647. doi:10.1007/s11277-022-09569-2.
4. Paul LC. The effect of changing substrate material and thickness on the performance of inset feed microstrip patch antenna. *Am J Netw Commun.* 2015;4(3):54–60. doi:10.11648/j.ajnc.20150403.16.
5. Kim KW, Cho YM, Hwang S, Park SO. Band-notched UWB planar monopole antenna with two parasitic patches. *Electron Lett.* 2005;41(14):783. doi:10.1049/el:20051090.
6. Kundu A, Chakraborty U, Bhattacharjee AK. Design of a compact wide band microstrip antenna with very low VSWR for WiMAX applications. *Int J Microw Wirel Technol.* 2017;9(3):685–690. doi:10.1017/S1759078716000374.
7. Luk KM, Mak CL, Chow YL, Lee KF. Broadband microstrip patch antenna. *Electron Lett.* 1998;34(15):1442–1443. doi:10.1049/el:19981009.
8. Sathamsakul S, Anantrasirichai N, Benjangkaprasert C, Wakabayashi T. Rectangular patch antenna with inset feed and modified ground-plane for wideband antenna. In: *Proc SICE Annual Conference*; 2008. p. 2847–2850. doi:10.1109/SICE.2008.4655253.
9. Singh G, Singh AP, Sharma NK, Singh VK. An innovative DGS based textile antenna with semi-circular slot for future IoT and AI applications. *Trans Electr Electron Mater.* 2023.
10. Dwivedi R, Srivastava DK, Singh VK. A nested orbicular shaped textile antenna with centered hexagonal slot, DGS and enhanced bandwidth for ISM, Wi-Fi, WLAN and Bluetooth applications. *Iran J Sci Technol Trans Electr Eng.* 2024;48:1393–1415. doi:10.1007/s40998-024-00729-7.
11. Verma RK, Priya B, Singh M, Singh P, Yadav A, Singh VK. Equivalent circuit model-based design and analysis of microstrip line fed electrically small patch antenna for sub-6 GHz 5G applications. *Int J Commun Syst.* 2023;36. doi:10.1002/dac.5595.
12. Dwivedi R, Srivastava DK, Singh VK. Novel miniaturized triangular slotted and DGS based inverted circular key shaped textile antenna with enhanced bandwidth for C, WLAN, RAS and N79 5G band applications. *Iran J Sci Technol Trans Electr Eng.* 2023;48:17–36. doi:10.1007/s40998-023-00651-4.
13. Singh VK, Naresh B, Verma RK. Parachute shape ultra-wideband wearable antenna for remote health care monitoring. *Int J Commun Syst.* 2023;36. doi:10.1002/dac.5488.
14. Yadav A, Singh VK, Yadav P, Beliya AK, Bhoi AK, Barsocchi P. Design of circularly polarized triple-band wearable textile antenna with safe low SAR for human health. *Electronics.* 2020;9:1366. doi:10.3390/electronics9091366.

How to cite this article:

Vishnoi MK, Ali Z, Singh VK, Verma AK. Design and development of a microstrip patch monopole antenna for wide band spectrum. *P-Edu International Journal of Multidisciplinary Studies* 2025; 1(1): 1-3.